

AMSTRAD



PPC 512S / 512D

PPC 640S / 640D

PERSONAL
PORTABLE COMPUTER

SERVICE MANUAL

CONTENTS

	Page
Technical Specification	2
Important Notes to Service Engineers	2
FD-5 Maintenance and Alignment Information	3 — 11
Exploded View 1	12
Exploded View 2	13
Circuit Board Views	14
Alignment Instructions	14
FD-5 Control Board Schematic Diagram	15
Cabinet Drawing & Parts List	16
CPU/Switch/Battery P.C.B.'s	17
Memory/Fuse/Volume P.C.B.'s	18, 19
Modem P.C.B. Component Layout	20
Keyboard Schematic Diagram	21
Chassis Schematic Diagrams	22 — 25
Power Supply Schematic Diagram	26
Modem Chassis Schematic Diagrams	27, 28
Electrical Parts List	29 — 31

TECHNICAL SPECIFICATION

PPC640

- Parallel Centronics Printer Port
- Compartment for 10 Alkaline C Cells to give up to 8 hours use.
- 8086 16-bit processor, 8MHz clock.
- 640k Ram, 64k Video Memory.
- Integrated display adaptor fully compatible with MDA and CGA. Drive either the LCD panel or an external monitor.
- 640 x 200 pixel supertwist LCD panel supports all CGA and MDA graphics and text modes. Display can be tilted to 6 viewing angles and contrast is fully adjustable to allow for different lighting conditions.
- Integral Modem which supports
 - V21 (300 bps) Full Duplex
 - V23 (1200/75bps)
 - V22 (1200 bps) Full Duplex
 - V22bis (2400 bps) Full Duplex
- Hayes Command compatible; auto-dialling, auto answer
- Includes Serial Port.
- AC Mains Adaptor.
- Enhanced AT type keyboard with 102 keys.
- Single or Twin 720K 3½ inch Disk Drives.
- Microsoft MS-DOS 3.3 Operating System.
- Mirror II Communications Software.
- Built-in Super Twist, 640 x 200 resolution, with grey scale emulation; hardware to drive any external CGA monitor.
- Speaker with volume control.
- Battery backed real time clock with scratchpad RAM.
- Socket for 8087 maths co-processor.
- Socket for PPC640 expansion box (to accept IBM compatible expansion cards and hard disk).
- Carrying case with pockets for manual and disks.
- Carrying size closed:
 - Length: 450mm (17 3/4") excluding handle.
 - Depth: 230mm (9")
 - Height: 100mm (4")
 - Weight: 5.4Kg (11 3/4lb) excluding batteries.

PPC512

- PPC512 specification as PPC640 but with 512K Ram and without integral modem and Mirror II Communications Software.
- Single or Twin 720K 3½ inch Disk Drives.

IMPORTANT NOTES TO SERVICE ENGINEERS

This Service Manual gives indepth technical information on all of the circuits and the P.C.B.'s which make up the PPC512/640. Much of this data is for information purposes only as the procedure engineers will follow when servicing this equipment will often be to exchange Printed Circuit Boards. In some instances Amstrad will insist that subassemblies are returned for exchange and should not be serviced by Service Engineers. Please take note of the following information before attempting to the service the equipment.

1. Full diagnostics are not specified in this manual. A diagnostic tool, designated the R.P.5-2*, is available from CPC and gives certain diagnostic information on the Computer. To carry out any indepth fault-finding this diagnostic tool is necessary.
2. The Disc Drive Mechanism and accompanying Printed Circuit Boards should not be serviced by Service Engineers. Exchange mechanisms complete with P.C.B.'s are available from Amstrad.
3. LCD Supertwist is a complete unit, and no service should be attempted on this unit by the field engineers. Exchange Display Assembly should be obtained from Service Department.
4. Complete Printed Circuit Boards are available on an exchange basis and unless the Service Engineer is particularly familiar with this product arrangements should be made to exchange the P.C.B.'s where a fault has developed. The R.P.5-2 diagnostic referred to above can be used to ensure correct diagnosis of the P.C.B. fault.
5. In some instances a second Disc Drive will be fitted to the PPC512/640. This second Disc Drive is subject to separate service information but under no circumstances should any service work be carried out on the mechanism or its Printed Circuit Board. In the event of a fault on the second Disc Drive arrangements should be made to exchange this.
6. Service Engineers carrying out any repairs on this unit can contact the Customer Services Section of Amstrad for further information should they have any difficulty.

The PPC512/640 is a sophisticated piece of computer technology and service work should be undertaken on this equipment by suitably qualified personnel and preferably by appointed Amstrad Agents.

*Upgrade kit is available to enable full diagnosis of the said machine.

**FD-5 MAINTENANCE AND ALIGNMENT INFORMATION
(FOR INFORMATION PURPOSES ONLY)**

1. OUTLINE OF MAINTENANCE

• The following tools are required for maintenance of a Floppy Disk Drive

1.1 Alignment Diskettes

Alignment diskette is used for head actuator alignment and index sensor alignment. Use the JU-01AA - DD and 817-363CE.

1.2 Exerciser

The exerciser enables you to make all adjustments and inspections necessary for an FDD. Its functions include the following:

- (1) Seek increment or alternate tracks
- (2) Read (but no data compare)
- (3) Write 1F or 2F (All 0's or 1's)
- (4) Recalibration to track 00

The exerciser has switches and indicators to execute a specified function.

2. DIAGNOSTIC PROCEDURES

2.1 Error Symptom Recognition

Errors that occur because of the wrong operating procedure, wrong programming, or use of a defective diskette, or soft errors due to external causes, such as contaminated air and random electrical noise, are often attributed to a drive failure.

Unless a visual inspection of the drive reveals an evident assembly fault or a defect, **always confirm errors with another good diskette, and another known good drive.**

2.2 Soft Error Detection and Correction

Soft errors are normally caused by the following:

- (1) Contamination between read/write heads and diskette. This kind of contamination can be easily eliminated by the liner in the diskette. Contaminated heads can be cleaned by a general purpose non-abrasive head cleaning diskette. Please follow the suitable procedure provided with the cleaning diskette.
- (2) Random electrical noise, normally a few microseconds or less.
- (3) Small defects in written data and/or track not detected during write operation may cause soft errors during read.
- (4) Faulty grounding of the drive or host system can also cause a soft error.
- (5) Wrong motor speed is another cause of soft errors.

Take the following steps on the controller side to recover from the soft errors mentioned above.

- (1) Read the track again ten times or until the data is recovered.
- (2) If Step (1) above fails to recover the data, access the adjacent track. Then return the head to the original track.
- (3) Repeat Step (1).
- (4) Any error that cannot be corrected by the above procedure is irrecoverable.

2.3 Write Error

If an error occurs during write operation, it is usually detected during the next revolution by performing a read operation called write check. To correct an error, write again and repeat a write check operation. If the result is unsatisfactory after ten or more write operations, perform a read operation on another track to determine whether it is the diskette or the drive that is wrong. If an error persists, replace the diskette and repeat the above procedure. If the error still persists, consider the drive defective. If the error is corrected, dispose of the diskette as defective.

2.4 Read Error

Most read errors are soft errors. Data can be recovered by following the recovery procedure mentioned in 2.2.

2.5 Seek Error

- (1) Stepper motor or stepper motor circuit drive is faulty.
- (2) Faulty Carriage

There are two ways of seek error recovery. One is to recalibrate to track 00, and seek back to the original track. The other is to read the ID field, check the track number on which the head is located, and move the head away from it. And read it again.

2.6 Interchangeability Error

Data which is written by one drive may not be read by another. This error is called an interchangeability error, which can be caused mostly by the following reason, which should be checked as follows.

- (1) Head misalignment: Refer to Adjustments and Confirmation Item 5.5
- (2) Head output too low: Refer to Adjustments and Confirmation Item 5.3
- (3) Motor speed difference: Refer to Adjustments and Confirmation Item 5.1
- (4) Format difference

3. TROUBLE ANALYSIS

3.1 Trouble Analysis Procedure

FDD trouble may occur in any of the following nine forms.

- (1) Index detection failure
- (2) Not ready
- (3) Track 0 undetectable
- (4) No seek
- (5) No write
- (6) No read
- (7) Read error
- (8) IN USE LED won't light
- (9) Write protect undetectable

CAUTION:

Be sure to switch power off before removing an FDD or PCB from the operating system.

3.1 TROUBLE ANALYSIS TABLE

Item	Trouble	No.	Cause	JU-3X2, 252A, 253A
1	Index Detection Failure	1	DD motor control PCB	Replace DD motor assembly
		2	DD motor faulty	Replace DD motor assembly
		3	Index LED faulty	Replace
		4	Index detector faulty	Replace
		5	PCB motor ON circuit	Repair
		6	PCB index detection circuit	Repair
2	Not ready	1	See Item 1	
		2	PCB ready circuit	Repair
3	Track 0 detection failure	1	Track 00 assembly	Replace
		2	PCB track 0 detection failure	Repair
4	No seek	1	Stepper motor	Replace
		2	Guide shaft contamination or damaged	Repair
		3	PCB stepper driver circuit	Repair
5	No WRITE	1	See Item 1	
		2	Head disconnected	Replace
		3	Head shorted	Replace
		4	PCB write circuit	Repair
6	No READ	1	See Item 1	
		2	See Item 5	
		3	PCB read circuit	Repair
7	READ ERROR	1	See Item 1	
		2	See Item 6	
		3	Alignment	Adjust
		4	Azimuth	Unadjustable
		5	Burst	Unadjustable
		6	Asymmetry	
		7	Limiter	Adjust
		8	Flag 0	Adjust
		9	Index period	Replace DD motor assembly
		10	PCB read circuit	Repair
8	IN USE LED won't light	1	LED part	Replace
		2	PCB IN USE circuit	Repair
9	Write protect failure	1	Write protect part	Replace
		2	Write protect circuit	Repair

4. PREVENTIVE MAINTENANCE

No preventive maintenance is necessary for any type of FDDs under normal conditions of use. However if it is determined that adjustments are necessary, the following must be done.

• Adjustments (Refer to table 4.1)

- (1) Specify an applicable model from Table 4.1, and make a read/write head radial adjustment at a specified track. (Sides 0,1)
- (2) Make an index timing adjustment at a specified track. (Sides 0,1).
- (3) Make an azimuth measurement at a specified track (Sides 0,1)

CAUTION

Do not write when using alignment diskette. Check that write protect sensor is properly operating with a data diskette. Note: Section 9 describes the adjustment procedures in detail.

5. ADJUSTMENTS AND VERIFICATIONS

5.1 Motor Speed Verification (Index Period)

- (1) Insert a diskette, run the motor, and clamp. Refer to the index period column of Table 4.1 for the applicable model.
- (2) Step to the specified track.
- (3) Connect a frequency counter to the INDEX signal. IX (INDEX)
- (4) Check that the frequency counter readings meet the specifications in the table.

5.2 Write Protect Verification

- (1) Check that the exerciser's write protect lamp goes on and off as a media is inserted and removed as specified in the table below.

Media with write protect hole open: ON
Media with write protect hole closed: OFF

5.3 Head Output Verification

Use a new diskette if possible to identify head failure for this check.

- (1) Insert a good diskette.
- (2) Run the motor.
- (3) Step to the track specified in the output level column of Table 4.1.
- (4) Connect the oscilloscope probe as specified below.

CH1 : T1
CH2 : T2
EXT : IX (Index)

Invert channel 2 and select the Add mode.

Set vertical deflection to 10mV/division and horizontal deflection to 20ms/division.

- (5) Write 2F (all ones) on the entire circumference.

- (6) Check that the average output level meets the specifications of Table 4.1. If it does not meet the specifications, refer to item 7 of the Trouble Analysis Table.

5.4 Output Modulation Verification

Modulation: M is calculated by the following formula.

$M(\%) = \frac{V_{max} - V_{min}}{V_{max} + V_{min}} \times 100$ using the value obtained in 5.3, and check that the calculated value is 20% or less.

$M(\%) = \frac{V_{max} - V_{min}}{V_{max} + V_{min}}$



Fig. 5.1 Modulation

3.2 Trouble Shooting Flow Chart

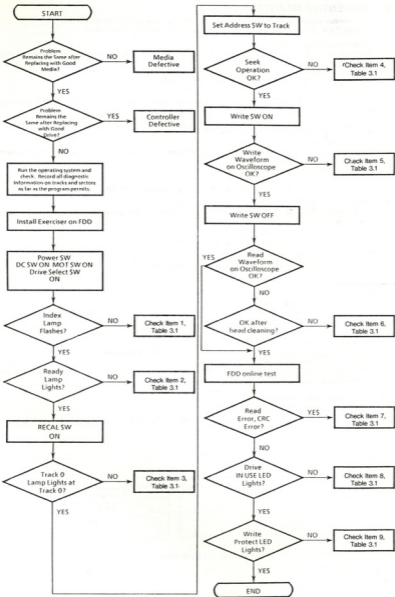

5.5 Radial Alignment Adjustment

Introduction

This adjustment is normally not necessary.

If the mounting screws for the stepper motor loosen, or if parts become defective, or if a compatibility error occurs, check and readjust according to the following procedure.

Steps (4) and (9) below should be performed regardless of the type, CE or DAD alignment diskette used. Use an alignment diskette suitable to the type of FDD to be adjusted according to table.

(1) Insert an alignment diskette.

CAUTION:

Be sure to leave the alignment diskette under room conditions for 20 minutes before adjustment.

(2) Step to the track specified in the Radial alignment column of Table 4.1.

(3) Leave the oscilloscope in the same condition as mentioned in section 5.3.

Cats Eye System

(4) Check the output waveforms for sides 0 and 1. They should appear as in Fig. 5.2.

(5) The two waveforms should appear in the amplitude ratio in the R/A +/- 42% or more.

(6) If the specified ratio is not satisfied, loosen the two mounting screws for the stepper motor.

(7) Move the stepper motor along the base by hand until the two waveforms assume approximately the same amplitude, and retighten the mounting screws. (See Fig. 5.2).

(8) Step the head outward (track 0) and inward (track 40 or 79), and confirm that the adjustment has been completed.

(9) After the initial adjustment, be sure to confirm track 00 sensor adjustment 5.8 and carriage limiter 5.9.

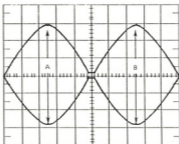

$$A > B : \frac{B}{A} \times 100$$
$$B > A : \frac{A}{B} \times 100$$

Fig. 5.2 Radial Alignment Waveforms (CATS EYE)

Note: Alignments on sides 0 and 1 are adjusted at the factory. If they are misaligned, adjust them to meet the specifications of Table .

DAD (Dynamic Alignment Diskette)

(4) Watch the output waveforms for sides 0 and 1. They should appear as shown in Fig. 5.3.

(5) Measure the timing levels A1 to A4 and B1 to B4 in Fig. 5.3, and calculate the lobe ratio from the following formulas.

$$\Sigma A \setminus \Sigma B : \frac{\Sigma B}{\Sigma A} \times 100\%$$

$$\Sigma A \setminus \Sigma B : \frac{\Sigma A}{\Sigma B} \times 100\%$$

(6) The lobe ratio calculated by the above formulas should meet the specifications on item 3 of Table.

(7) If the above requirement is not met, loosen the two mounting screws for the stepper motor, adjust.

(8) Seek from track 0 to track 40 and from track 79 to track 40, and confirm that the adjustment has been completed.

(9) After the radial adjustment, be sure to confirm track 00 sensor adjustment 5.8 and head carriage limiter 5.9.

Note: An alignment instrument for 3.5 inch FDDs permits accurate and easy adjustment because the lobe ratio is displayed on the instrument.

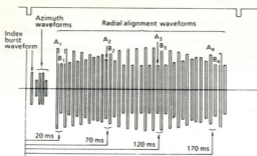

Fig. 5.3 Alignment Waveform (DAD)

5.6 Azimuth Verification

- (1) Insert an alignment diskette. Seek to the track specified in the azimuth column of Table 4.1.
- (2) Set the oscilloscope in the same conditions as in 5.3., and set horizontal deflection to 2ms/div (DAD) or 0.5 ms/div (CE).
- (3) Measure as shown below.
- (4) Confirm that the measured value meets the specifications in the azimuth column of Table 4.1.

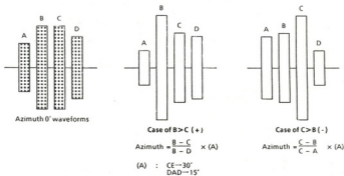

Fig. 5.4 Azimuth Waveforms

5.7 Index Burst Verification and Adjustment

- (1) Insert an alignment diskette. Seek to the track specified in the I/B column of Table 4.1.
- (2) Set the oscilloscope time base as follows: 1ms/division.
- (3) Check that the time from oscilloscope start to the first data pulse meets the I/B specifications of Table 4.1. (DAD SYSTEM).

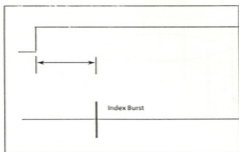

Fig. 5.5 Index Timing

5.8 Track 00 Sensor Adjustment

(1) Set the oscilloscope as follows:
Set horizontal deflection to 1ms/division.

CH1 : ZP

EXT : SP

(2) Step between specified tracks at in the FLAG 0 item of Table 4.1. (Turn the seek delay switch on the exerciser to adjust 12ms seek).

(3) Loosen the track 0 sensor screw and adjust until the waveform on the oscilloscope appears as shown in Fig. 5.6.

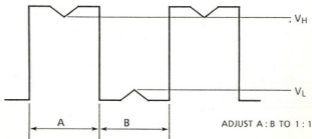

Fig. 5.6 Track 0 Waveform

5.9 Limiter Verification

(1) Seek to track 0.

(2) Write 2F data on track 0, and measure read level.

(3) Seek to track -1, and check that the head just touches the limiter.

(4) Check that, when the RECAL switch on the exerciser is pushed ON, the head returns to track 0 and that the 2F output level is the same as that measured in Step (2).

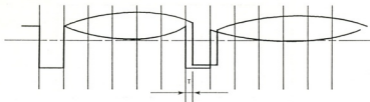

Fig. 5.7 Asymmetry Waveform

(Asymmetry Wave form might be reversed up-and-down from model to model)

5.10 Asymmetry Verification

- (1) Insert a data diskette.
- (2) Step to the track specified in the symmetry item of Table 4.1.
- (3) Set the oscilloscope as follows:

CH1 : RD

CH2 : T1

Set time base to 1 μ s/division and vertical deflection to 0.2 v/division.

- (4) Write 1F.
- (5) A read wave form is displayed on the oscilloscope as shown in Fig. 5.7.
- (6) Confirm if it satisfies the value as shown in Table 4.1.

(Asymmetry wave form might be reversed up-and-down from model to model).

ALIGNMENT CASSETTE

3.5 inch Alignment Diskette

TP1	P/N	Index Burst	Azimuth	Radial Alignment	MODEL
135 DAD	JU-01AA	40TRK	40TRK	40TRK	JU-252A
135 CE	817-363CE				JU-253A

MEASUREMENT ITEMS TABLE 4.1

Item	Parameter	JU-252A, 253A	
		TRK	Value
1	Index Period	40	200 \pm 2ms
2	Output Level	79	80mV or more
3	Radial Alignment Reference (DAD) Reference (CE by 817-363CE)	40	\pm 35 μ m (29% or more) (42% or more)
4	Azimuth	40	\pm 24'
5	Index burst	40	3 \pm 1.7ms
6	Flag 0	From track 0 to track 1 and back	TR00 (TR00: Low, Tr1: Height)
7	Limiter	-1	Recalibrate and return to 0
8	Asymmetry	79	\leq 700NS

TEST POINTS

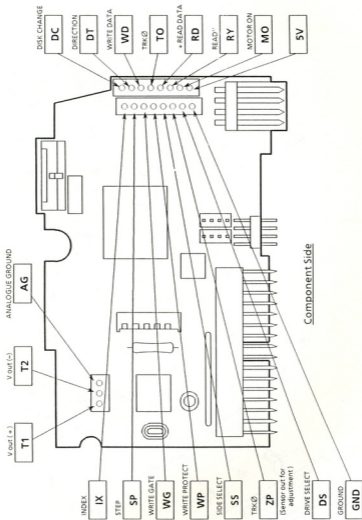

EXPLODED VIEW — 1

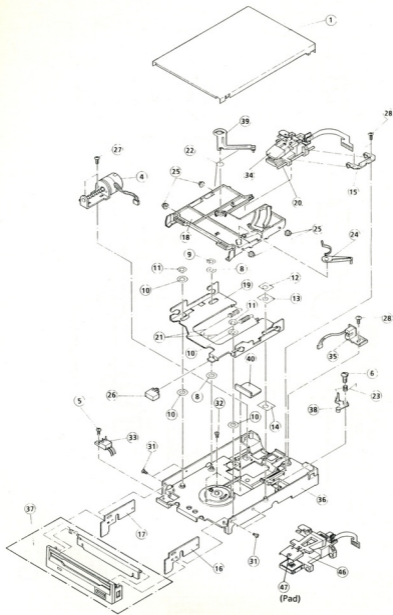

EXPLODED VIEW - 2

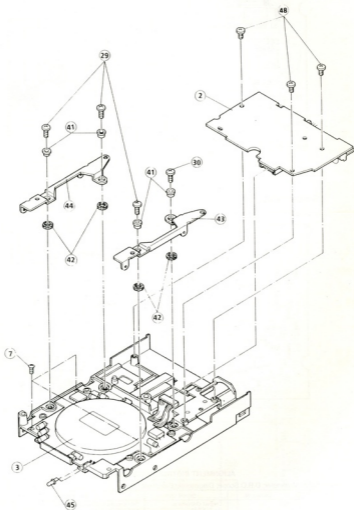

CIRCUIT BOARDS

Component Side

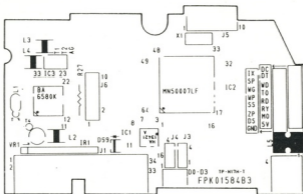

Solder Side

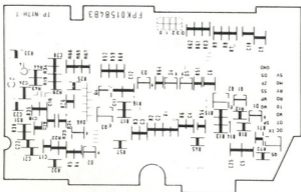

ALIGNMENT INSTRUCTIONS FOR PPC512/640

Equipment required: Digital Multimeter; D.B.O. Scope; Diagnostic Disc/Tool.

Step	FUNCTION	SIGNAL IN	SIGNAL OUT	METHOD	REMARKS
1.	Set RTC	X-103	Connect Odometer to Pin 21 IC134.	Set Odometer to 0.2sec/Day. Adjust it to read 0.00 with TC101.	Do this adjustment only if the real timeclock chip is changed.
2.	Set +5V.	Power On.	Junc. of LS01 & CS14.	Adjust VR501 to get 5V ± 0.5%.	Use Power Adaptor to power PPC.

FD-5 SCHEMATIC DIAGRAM

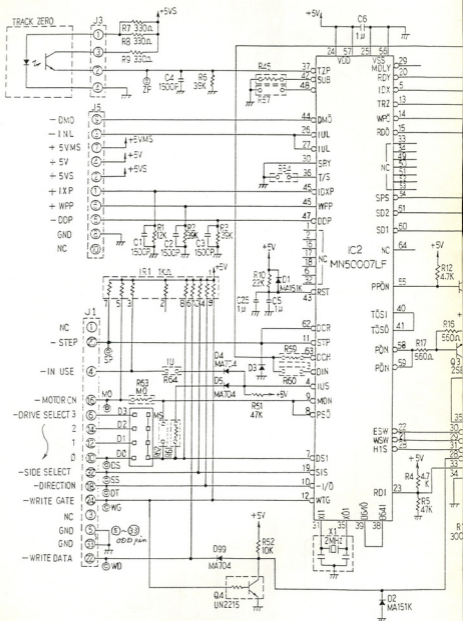

RAM OF CONTROL BOARD

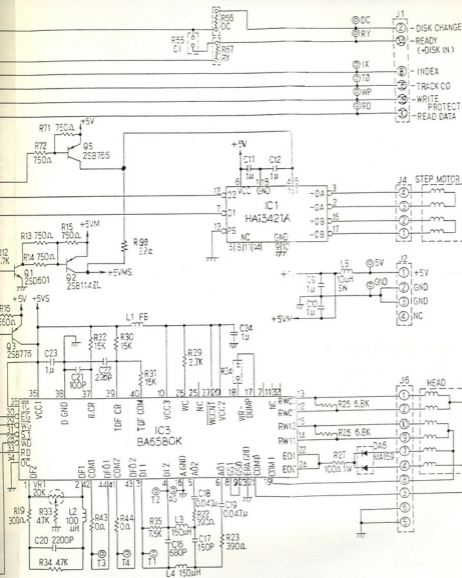

CABINET DRAWING PPC 512/640/S/D

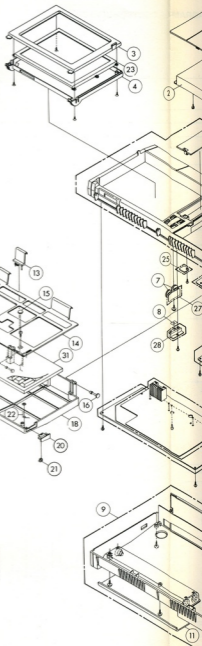

CABINET PARTS LIST PPC512 S/D, PPC640 S/D

Ref.	Description	Part No.	Part No.
		PPC512S/D	PPC640S/D
1	Cover FDD	177201	177202
2	Frame FDD	177203	177204
3	Cabinet Top LCD	177205	177206
4	Cabinet Bottom LCD	177207	177208
5	Cabinet Main Top Ass'y	177209	177210
6	Lid Compartment	177211	177212
7	Knob Volume	177213	177214
8	Cover Power Switch	177215	177216
9	Cabinet Main Bottom Ass'y "S"	177217	177218
	Cabinet Main Bottom Ass'y "D"	177217/A	177218/A
10	Expansion Connector Door	177219	177220
11	Lid Battery	177221	177222
12	Handle	177223	177224
13	Lid Key Board	177225	177226
14	Cabinet Top Key Board	177227	177228
15	Screw Cap	177229	177230
16	Stud (A)	177231	177232
17	Stud (B)	177233	177234
18	Cabinet Bottom Key Board	177235	177236
19	Knob Slide (L)	177237	177238
20	Knob Slide (R)	177239	177240
21	Holder Slide Knob	177241	177242
22	Spring Slide Knob	177243	177244
23	Super Twist LCD Screen	177245	177245
24	FD-5 Floppy Disc Drive	177247	177248
25	PCB LED	177249	177249
26	PCB Fuse	177251	177251
27	PCB Volume/Contrast	177253	177253
28	Slide Switch Power On/Off	177255	177255
29	PCB Power Supply/Memory	177257	177257
30	PCB CPU Ass'y	177259	177259
31	Blanking Cover "S"	177261	177262
32	PCB Modem		177322

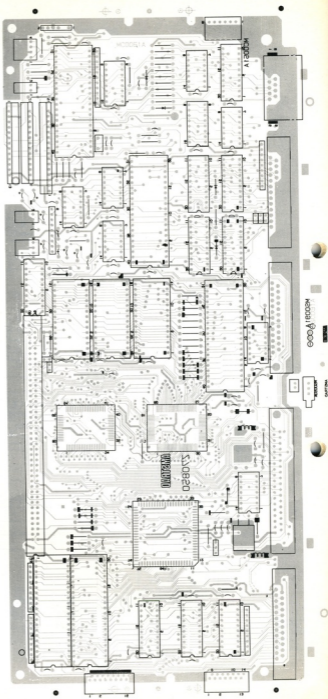
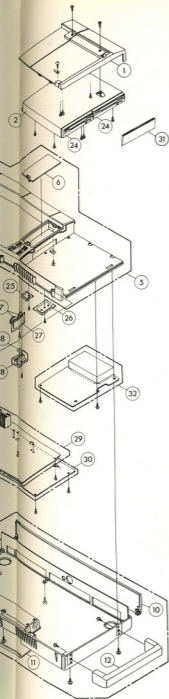

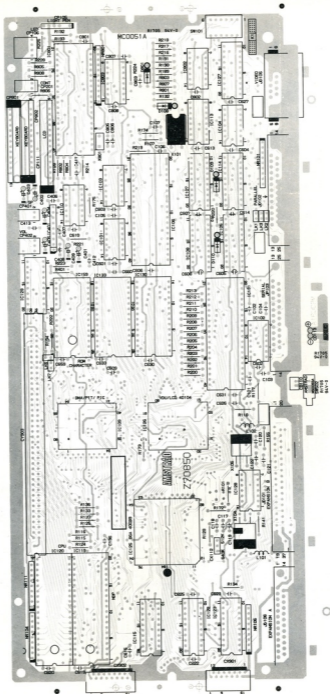

CPU/SWITCH/BATTERY P.C.B.s

MEMORY/FUSE/VOLUME P.C.B.

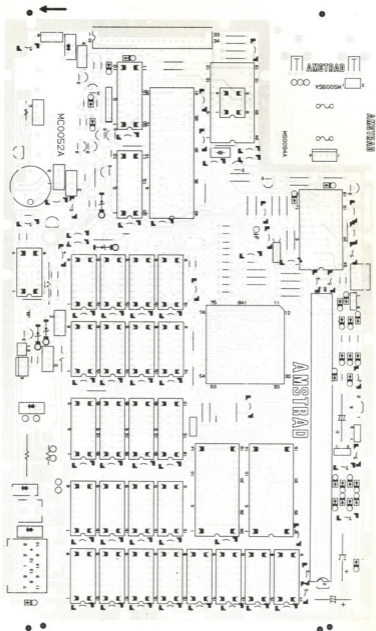

MODEM P.C.B. COMPONENT LAYOUT

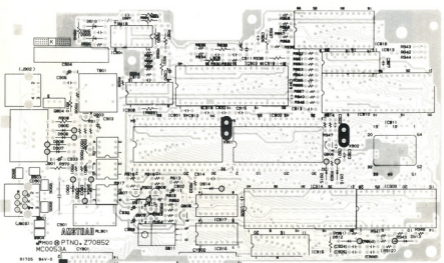
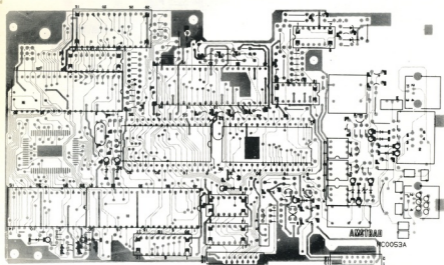

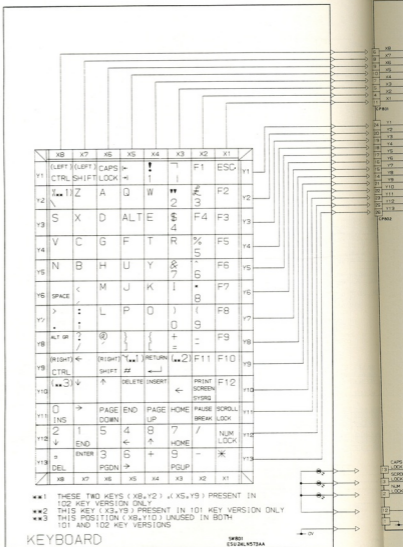

SCHEMATIC DIAGRAM

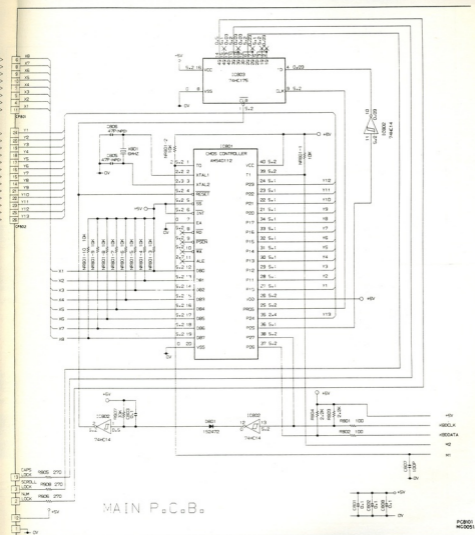

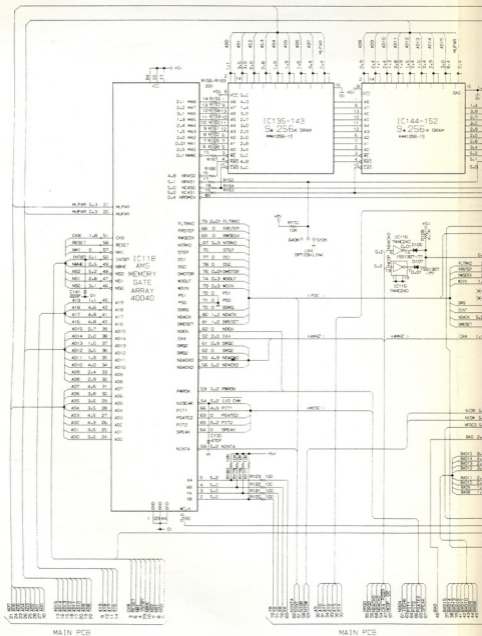

MAIN PCB

MAIN PCB

SCHEMATIC DIAGRAM

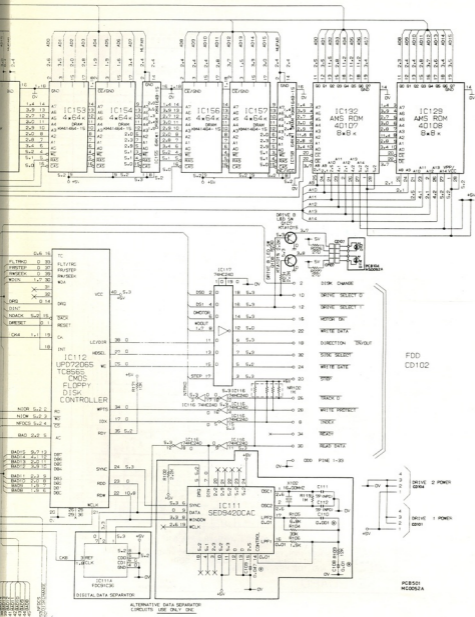

FDD
CD102

DRIVE 0 POWER
DRIVE 1 POWER

PC8501
MCD02A

ALTERNATIVE DATA SEPARATOR
CIRCUITS USE ONLY ONE

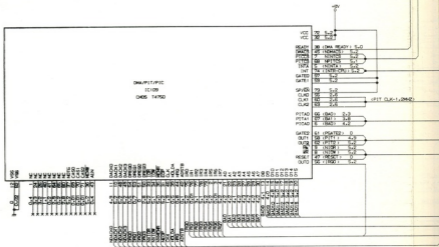
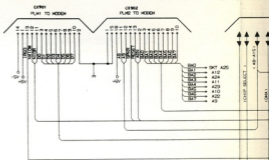

CHEMATIC DIAGRAM

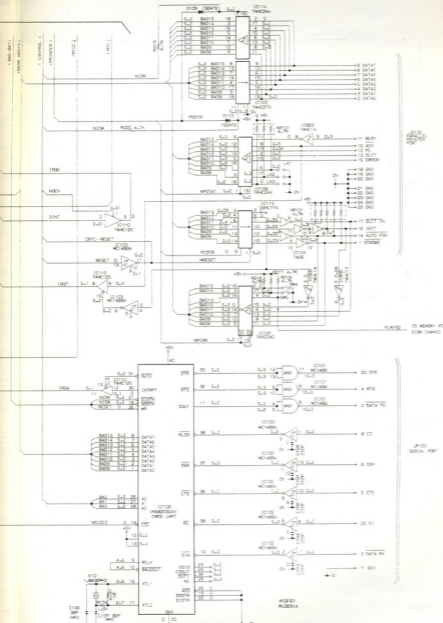

NOTE THIS SCHEMATIC DIAGRAM IS THE LATEST AT THE TIME OF PRINTING AND SUBJECT TO CHANGE WITHOUT NOTICE.

POWER SUPPLY SCHEM

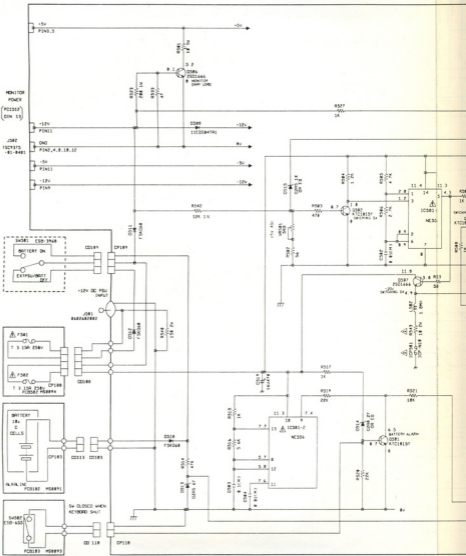

NOTE F3M3A IS OR S407T1
 11084 IS OR S407T1
 110284T1C (TAPPING)

+1 0285 258875 = 2550443 (FULL PACK)

CAUTION: SINCE THESE PARTS MARKED WITH A TRIANGLE ARE CRITICAL FOR SAFETY USE ONLY DESCRIBED ON PARTS LIST ONLY.

REF 10320: LES P
 ORDER IN S
 09/11/2001

LY SCHEMATIC DIAGRAM

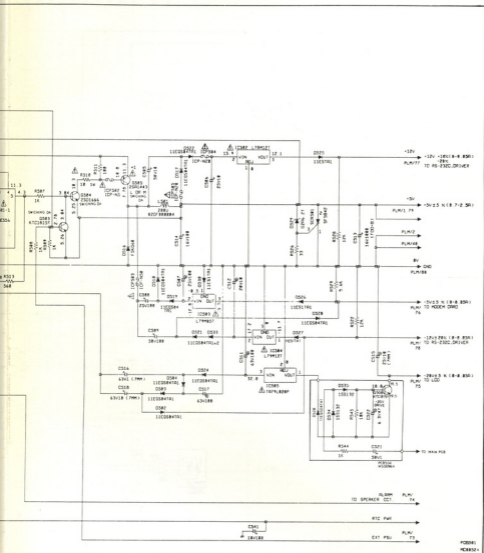

ATTENTION: LES PIÈCES MARQUÉES PAR UN ET/OU UN DOIVENT ÊTRE ACQUISES EN POINT DE VUE SÉCURITÉ. N'UTILISER QUE DES PIÈCES IDENTIFIÉES DANS LA NOMÉCLATURE DES PIÈCES.

NOTE: THIS SCHEMATIC DIAGRAM IS THE LATEST AT THE TIME OF PRINTING AND SUBJECT TO CHANGE WITHOUT NOTICE.

FORM 40
REV 8/82

SCHEMATIC DIAGRAM

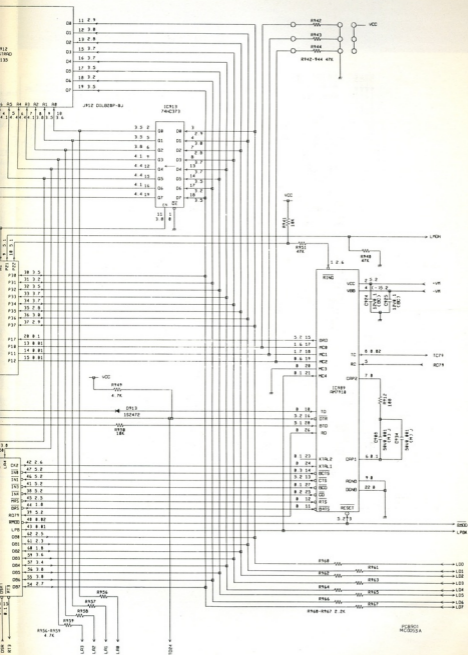

MODEM CHASSIS SCHEMATIC DIAGRAM (2)

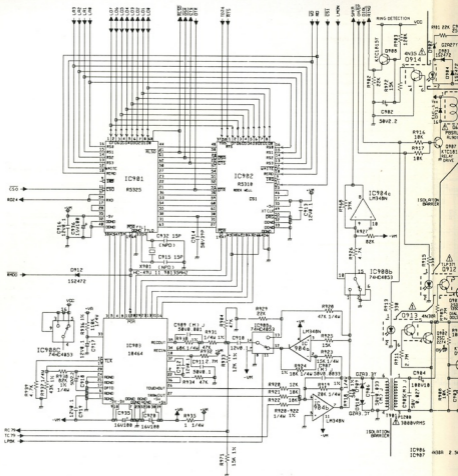

PIN OUT CONFIGURATION OF MODEM I.C.s

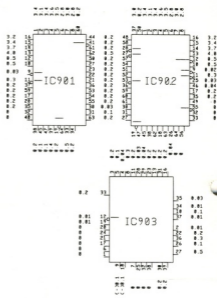
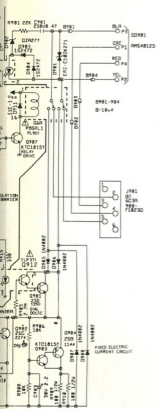

Q912 1 2 4 5 6 8 8 8 8 8 8 8 8	Q981 C C 0 8 8 8 8 8 8 8 8	Q984 E C 0 8 0 8 8 8 8 8 8
Q913 1 2 4 5 6 8 8 8 8 8 8 8 8	Q982 C C 0 8 8 8 8 8 8 8 8	Q987 E C 0 8 5 2 8 8 8 8 8
Q914 1 2 4 5 6 8 2 8 8 8 8 8 8	Q983 E C 0 8 8 8 8 8 8 8 8	Q988 E C 0 4 4 5 2 5 8 8 8
IC984a 1 2 3 4 8 8 8 8 8 8	IC985a 7 8 11 12 13 14 (-) 8 1 0 8 4 0 8 8	
IC984b 5 6 7 11 8 8 8 8 8 (-) 8 1	IC985b 1 2 6 10 15 8 8 8 8 5 1 8	
IC984c 8 9 10 8 9 (-) 8 1 8	IC985c 3 4 5 9 16 5 2 5 2 5 2 5 2	

ELECTRICAL PARTS LIST

Description	Circuit Reference	Part No.
Resistors		
(All resistors are 1/4W unless otherwise stated)		
1Ω 1/6W	R935	152138
2.2Ω	R973	177338
33Ω	R124, 156-169, 526	10018
47Ω 1/6W	R533	152160
56Ω	R229, 502	10024
68Ω	R172, 173	10028
100Ω 1/6W	R912	152215
100Ω	R120-123, 128, 132, 511, 801, 802	10032
100Ω 1/4W	R909, 910	177339
270Ω	R225-228, 805, 806, 808	10042
330Ω	R913, 915	152172
470Ω	R503	152174
560Ω	R513	10050
680Ω	R125	10052
1kΩ	R507-509, 515, 517, 527, 544	152179
1.2kΩ	R504	10063
1.5kΩ	R106, 174	10065
2.2kΩ	R102, 133, 134, 136, 137, 230, 803, 804	10069
2.2kΩ 1/6W	R231, 960-967	152183
Ω 1/6W	R506	152184
Ω	R200-213	10073
4.7kΩ 1/6W	R139, 505, 926, 939, 949, 953, 955-959	152188
4.7kΩ	R101, 108, 117, 118, 189-194, 214, 216-220, 222	10077
5.6kΩ 1/6W	R516, 529	152189
6.8kΩ	R105	10081
10kΩ 1/6W	R140, 177, 521, 545, 906, 908, 914, 916, 917, 941, 947, 948, 950, 952, 954, 969	152194
10kΩ	R129, 138, 150, 170, 171, 178-180	10085
12kΩ	R103, 109, 116	10087
12kΩ 1/6W	R522, 528	152195
15kΩ	R115, 154	10089
15kΩ 1/6W	R925, 972	152196
22kΩ	R195	10093
22kΩ 1/6W	R519, 520, 901, 902, 929	152189
33kΩ	R104, 807	10097
39kΩ	R968	152201
39kΩ	R224	10099
47kΩ	R514, 904, 928, 934, 940, 942-944, 951	152203
Ω	R927	152207
Ω	R175, 221, 223	10109
120kΩ	R903	152210
150kΩ	R149	152211
270kΩ	R135	152214
1MΩ	R107, 119, 141, 155	10147
2.2MΩ	R143	152227
2.7MΩ	R905, 911, 932	152228
10MΩ	R148	152132
Metal Film Resistors		
(All resistors are 1/4W unless otherwise stated)		
300Ω	R151, 152	177344
560Ω	R918	177345
1.8kΩ	R176	177346
12kΩ	R542, 920, 933	177347
15kΩ	R923, 971	177348
18kΩ	R921, 922, 924	177349
20kΩ	R919	177350
27kΩ	R188	177351
43kΩ	R937	177352
47kΩ	R931	177353
68kΩ	R930	177354
82kΩ	R938	177355
100kΩ 1/6W	R146, 147	177356
110kΩ	R936	177357
430kΩ 1/6W	R144	177358
560kΩ 1/6W	R145	177359

Description	Circ. Ref.	Part No.
Metal Oxide Resistors		
10Ω 1W	R510	177360
10Ω 2W	R543	177361
150Ω 2W	R544	177362
220Ω 1W	R523	177363
Cement Resistors		
10Ω 5W	R501	177340
Variable Resistors		
VR101	VR Rotary 10kΩ	177341
VR401	VR Rotary 20kΩ	177342
VR501	VR SF 5kΩ	177343
Ceramic Capacitors		
7pF NPO	C111, 112	177364
8pF NPO	C119, 122	177365
10pF NPO	C322	177366
15pF NPO	C315, 932	177367
18pF NPO	C117, 121	177368
22pF NPO	C921	177369
33pF NPO	C116	177370
39pF NPO	C106, 914	150508
47pF NPO	C805, 806	175128
82pF NPO	C107	150507
100pF NPO	C115	177373
100pF	C138, 807	24016
220pF	C101-105, 128	400107
470pF	C135, 408	150496
0.001μF	C411	150518
0.1μF	C113, 123, 129, 132, 601-620, 622, 623, 625-627, 630, 631, 633-661, 801-803, 808, 910-913, 916, 917, 919, 923-928	20062
Electrolytic Capacitors		
1μF/50V	C401, 405, 521	20062
1μF/63V	C516	177374
2.2μF/50V	C902, 903, 918	151598
10μF/25V	C508, 515	171801
10μF/50V	C505, 512	177375
10μF/63V	C518	177376
10μF/100V	C904	177377
22μF/25V	C409	177378
47μF/16V	C114, 402, 404, 522	20027
100μF/16V	C541, 920, 929, 935, 936	20028
100μF/25V	C507, 508	177379
100μF/50V	C509	177380
100μF/63V	C511, 517	177381
470μF/16V	C519	1422248
1000μF/10V	C140, 403, 930	171605
1000μF/16V	C513, 514	1400345
4700μF/16V	C139	170613
Polyester Capacitors		
(Working voltage of all Capacitors is 50V DC)		
0.001μF	C110, 412, 908, 909, 934	171093
0.003μF	C907	151600
0.01μF	C108, 118, 120, 138, 408, 502, 504	171236
0.022μF	C413	177382
0.027μF	C905	177153
0.033μF	C906	177383
0.047μF	C109	170422
0.068μF	C407	177384
0.1μF	C503	177155
Metal Polyester Capacitor		
0.47μF/250V	C901	177385

ELECTRICAL PARTS LIST

Circ. Ref.	Description	Part No.
Diodes		
D101-110	D 1SS132T-77	171552
D111	LED SLP-155B	170866
D112, 113	LED SLP-251B	177270
D114	LED SLP-451B	177271
D502-504, 508, 517-522, 524, 528, 533	D Shottky 11EQS04TA1	177272
D510-512, 516	D Shottky Barrier F5KQ60	171496
D513	DZ GZA5.6Y BT	171499
D514	DZ GZA8.2Y BT	177274
D515	DZ GZA5.1X BT	1422112
D525-527, 530	D 11ES1TA1	171551
D529	DZ GZA6.2Y BT	177275
D534, 535, 801	D 1S2472T-77	175050
IC's		
IC101	IC MC1488P	171378
IC102, 103	IC MC1489	171379
IC104	IC HD7406P	171380
IC105, 160	IC SN74HC273N	177277
IC106, 914	IC INS82C50	171381
IC107	IC LC74HC240	177278
IC108, 114, 115, 127	IC LC74HC244	177279
IC109	IC T4750	40111
IC110	IC LC74HC125	177281
IC111	IC SED9420CAC	171034
IC112	IC TC8565P	177282
IC113	IC LC74HC174	177283
IC116, 117	IC TC74HC240P	177278
IC118	IC AMS40040	171391
IC120	IC CXG070116P-8	177284
IC122	IC SN74LS373N	170106
IC123, 915	IC LC74HC245	177285
IC125	IC HSG5140/AMS40039	171577
IC126	IC AMS40104	40104
IC128	IC LC74HCUD4	40008/A
IC129	IC AMS40108	40108
IC130, 133	IC LC3664-10	177286
IC131	IC UM8845/AMS40072	170106
IC132	IC AMS40107	40107
IC134	IC MC146818P	171399
IC135-152	IC KM41256-15	171400
IC153-158	IC KM4164B-15	175005
IC159	IC AMS40109	40109
IC401	IC LA4160	170111
IC501	IC NE558CN	177288
IC502	IC L78M12T	190062
IC503	IC L79M05T	177289
LC504	IC L79M12T	177290
IC505	IC TA79L020P	177291
IC801	IC AMS40112	40112
IC802	IC LC74HC14	171033
IC803	IC LC74HC175	177292
IC901	IC R5325	177293
IC902	IC R5310	177294
IC903	IC 10464	177295
IC904	IC LM348N	177296
IC906	IC TC74HC4053AP	177297
IC909	IC AM791P	177298
IC910	IC HD63A01V1G93P	177299
IC911	IC AMSTRAD 40102	40102
IC912	IC AMSTRAD 40135	40135
IC913	IC LC74HC373	177300
IC916	IC LC74HC30	177302
IC917	IC LC74HC00	177303

ELECTRICAL PARTS LIST

Circ. Ref.	Description	Part No.
Transistors		
Q101, 102, 105, 501-503, 508, 903, 905-909	TR KTC1815Y	170447
Q103, 104, 106-108	TR KTA1015Y	170453
Q504, 506, 507	TR 2SD1666R	177304
Q505	TR 2SA1443L	177305
Q901	TR 2SD1350	177306
Q902	TR 2SC2274	150566
Q904	TR 2SB1144	177307
Q910	TR Field Effect MPF930	177308
Q911	TR Field Effect MTP8P08	177309
Q912	TR Photo Coupler TLP371	177310
Q913	TR Photo Coupler 4N38A	177311
Q914	TR Photo Coupler 4N35	177312
Coils		
L101, 102	Coil 2.2uH	175024
L501	Coil 200uH	1507
L502	Coil 1.8uH	162
T901	Line Transformer P-1200	177313
Jacks		
J501	Jack DC	170834
J502	Jack DIN	171437
J901	Socket Telephone 900-71023D	177314
Switches		
SW101	Slide Switch A6DR-6100	177315
SW501	Slide Switch Power On/Off	177316
SW502	Push Switch Sensor	177317
SW801	Switch Key Board PPC512	177318
	Switch Key Board PPC640	177319
PCB's		
PCB101	PCB CPU MC0051A	177259
PCB102	PCB Switch Micro	177320
PCB103	PCB Switch	177255
PCB104	PCB LED	1772
PCB501	PCB Memory and Power Supply MC0057A	177
PCB502	PCB Fuse	177251
PCB503	PCB Volume Control	177253
PCB504	PCB Control	177321
PCB901	PCB Modem MC0053A	177322

ELECTRICAL PARTS LIST

Circ. Ref.	Description	Part No.
Miscellaneous		
AD501	AC Adaptor	177323
	Cigarette Lighter Cable	177324
	Modem Extension Cable	177325
FDD201	Floppy Disc Drive PPC512	177247
	Floppy Disc Drive PPC640	177248
ICP501	ICP-N10	177326
ICP502	ICP-N5	177327
ICP503	ICP-N50	171547
ICP504, 505	ICP-N20	150442
JD101	Socket D-Sub 37 Way Expansion A	177386
JD102	Socket D-Sub P. Printer	171433
JD105	Socket D-Sub Video	175131
JD106	Socket D-Sub 25 Way Expansion A	177387
JP103	Socket D-Sub S. Printer	171438
LCD101	LCD Super Twist Display	177245
NR101, 105	Resistor Network 4.7k Ω x 8	171670
NR102	Resistor Network 1k Ω x 4	177328
NR104, 111	Resistor Network 2.2k Ω x 8	177329
NR801	Resistor Network 1k Ω x 8	171058
SP101	Speaker	171370
SCR501	Thyristor SF5B42	177331
TC101	Trimmer Capacitor 200pF	171371
X101	Crystal HC49U.843M	171372
X102	Ceramic Oscillator CSA16.00MX7	177332
X103	Crystal DSVT30032K	171374
X104	Crystal HC49U24M	177333
X105	Crystal HC49U28.63636M	177334
X801	Ceramic Oscillator KBR6.00MM	171377
X901	Crystal HC-49/U 11981.35	177335
X902	Crystal HC-49/U 14745.6k	177336
RL901	Relay G6A-234P-BS	177337
	Carry Case	177388
	MSDOS System Disc 3.3	48001
	Mirror Soft Disc	48003

AMSTRAD PLC
BRENTWOOD HOUSE, 169 KINGS ROAD, BRENTWOOD, ESSEX CM14 4EF.
Telephone: 0277 230222. Telex: 995417 AMSELE G.